

Audio Signal Flow in the Mackie Mixer

- Page 2:
 - Feed to the Main Audience Speakers
 - Flow to the Stage Monitors
 - Flow to the headset when a channel is in SOLO
- Page 3 and 4:
 - Signal flow through an input channel

Block Diagram CFX MKII Series

Signal Flow

Jamie 20241108

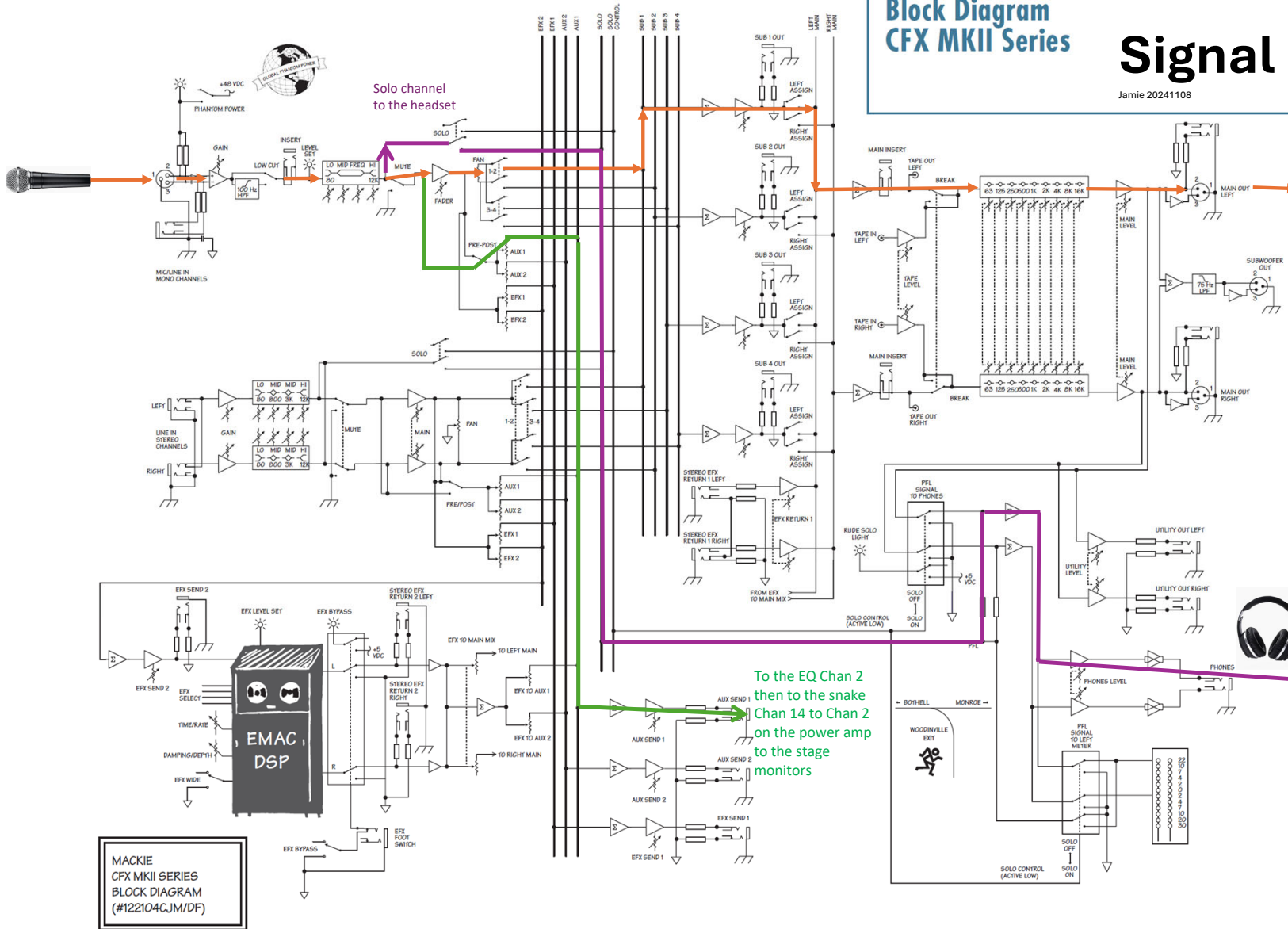

MACKIE
CFX MKII SERIES
BLOCK DIAGRAM
(#122104CJM/DF)

Mixed Output labeled "A". To the EQ Channel 1 then to the snake Channel 13 to the main speakers

Solo channel to the headset.
When SOLO is engaged on a channel, the main mix is replaced by the solo channel so that you can fine tune EQ, levels, distinguish between instruments, etc.

To the EQ Chan 2 then to the snake Chan 14 to Chan 2 on the power amp to the stage monitors



Microphone signal from the snake → into the Mixer (XLR-3)

Music or other signal from iPhone, mp3 player, etc. (1/4" trs) →

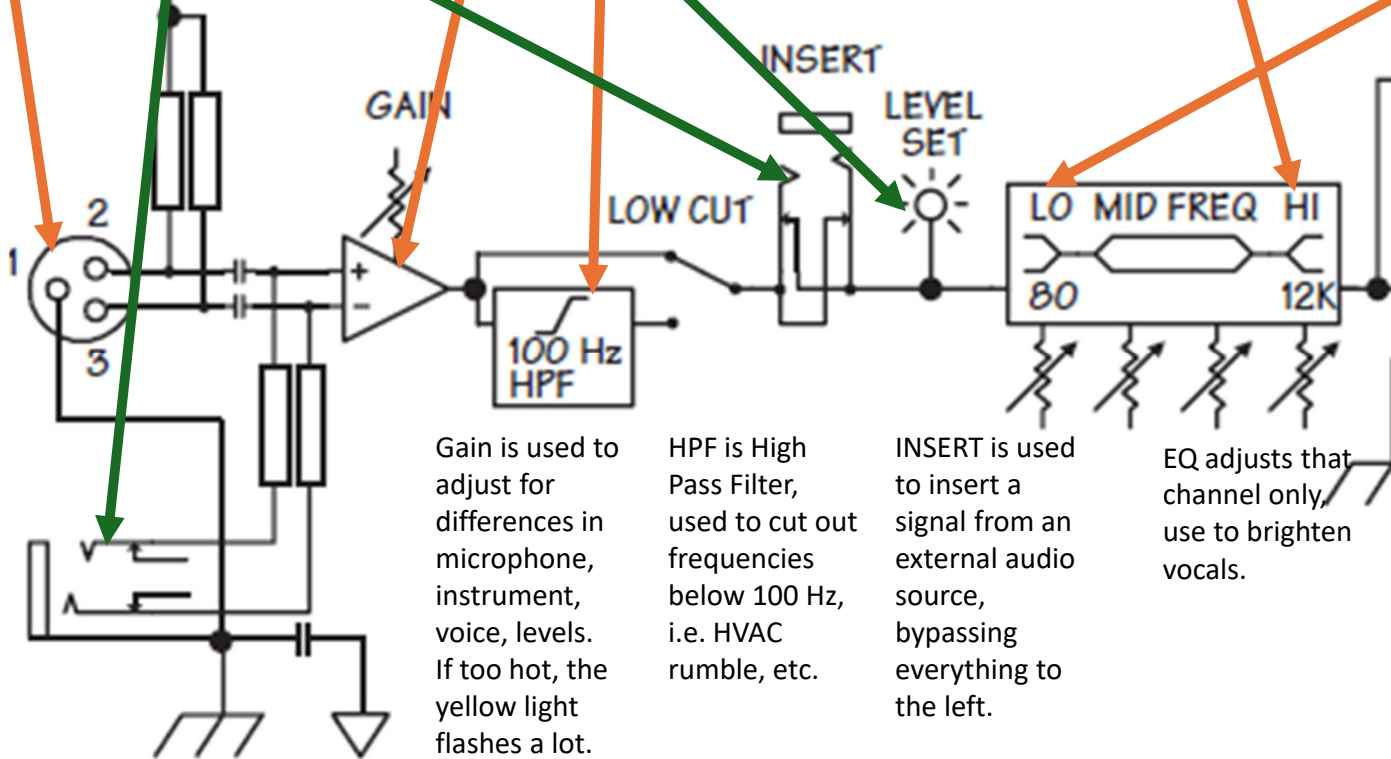

Gain is used to adjust for differences in microphone, instrument, voice, levels. If too hot, the yellow light flashes a lot.

HPF is High Pass Filter, used to cut out frequencies below 100 Hz, i.e. HVAC rumble, etc.

INSERT is used to insert a signal from an external audio source, bypassing everything to the left.

EQ adjusts that channel only, use to brighten vocals.

Send to AUX or EFFECTS

Mix Volume and Assign to Outputs



EFX 2 Effects sends the signal to the EMAC DSP (reverb, echo, etc.) module. From there, the effect can be mixed back into the LEFT and RIGHT MAINS outputs.

EFX 1 is used to feed an external effects system.

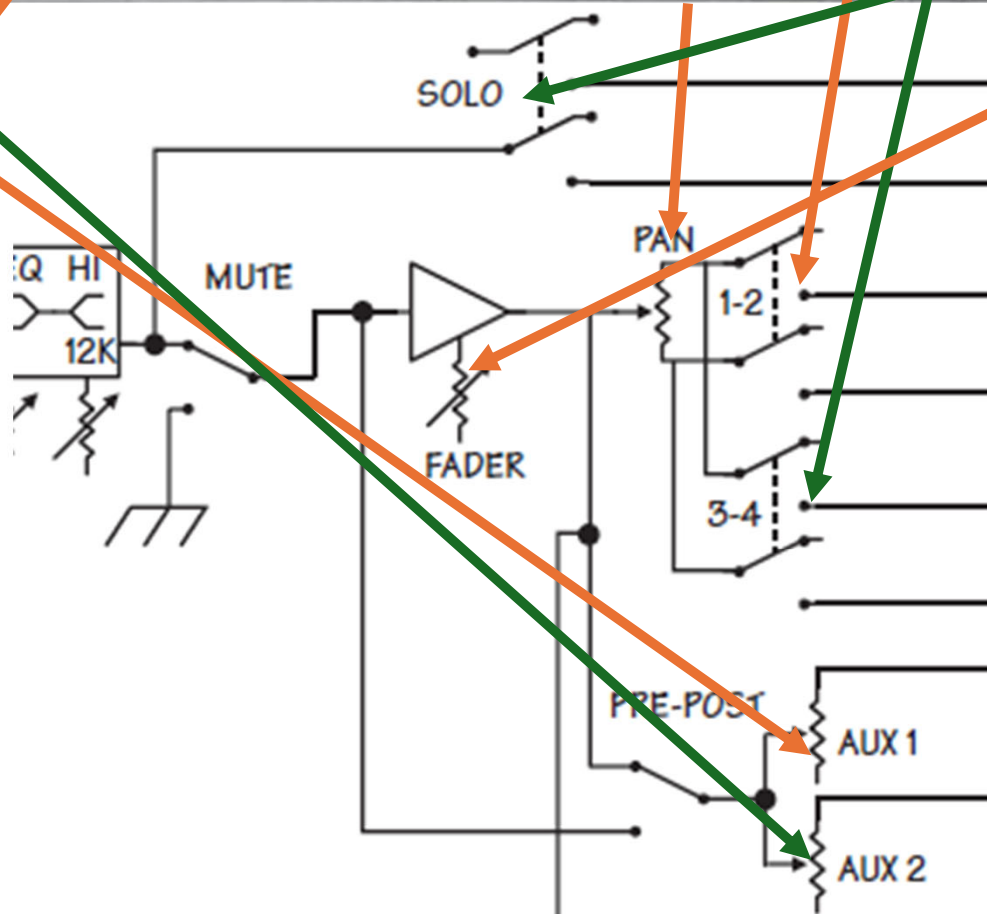

ASSIGN 1-2 and 3-4 feed to the master faders labeled the same name. The signal then goes to the outputs by this label and to the MASTER fader and its output jacks.

AUX 1 and 2 feed to the gain controls for these two channels, then to the output jacks labeled the same.

Block Diagram CFX MKII Series

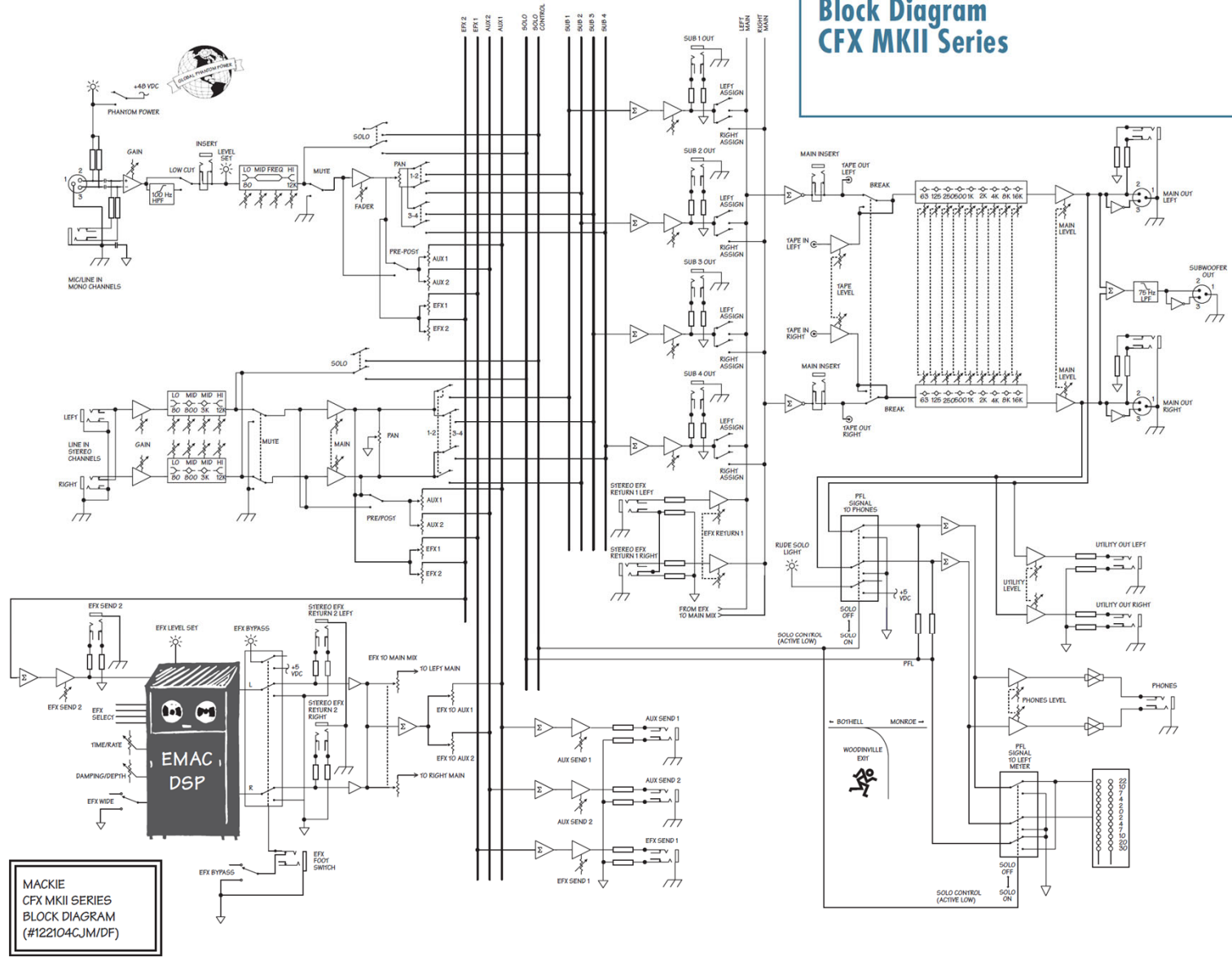

MACKIE
CFX MKII SERIES
BLOCK DIAGRAM
(#122104CJM/DF)